

CONFIGURATOR SOLUTIONS

Empower Every Quote with Intelligence and Speed

Configurator Solutions is a trusted provider of advanced configurator and CPQ (Configure, Price, Quote) software tailored for the fluid handling and broader manufacturing industries. With over two decades of experience, we have helped manufacturers-from global enterprises to growing businesses-optimize their sales and engineering processes through intelligent automation. Our CPQ application delivers end-to-end solutions for product sizing, selection, configuration, pricing and automated quote-to-order generation. Seamlessly integrated with leading enterprise platforms such as SAP, Microsoft and Salesforce, it ensures efficient operations and a unified digital experience. Designed with industry-specific needs in mind, our solution enhances quote accuracy, reduces turnaround time and improves overall productivity.

OUR VISION

Our goal is to assist manufacturers leverage our product configurators to automate the complete sales process from **Quote-to-Order** in a smooth & intuitive manner through proven software technology & industry expertise. Our CPQ solution facilitates collaboration between Sales, Costing, Engineering, Product Management and Order Processing by integrating CRM-CPQ-ERP seamlessly.

CONTACT US

Shoppers Orbit
Alandi Road
Pune, India
sales@configuratorsolutions.com
www.configuratorsolutions.com

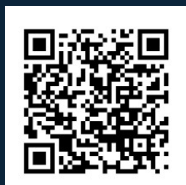

SIZING AND CPQ FOR

- Control Valves
- Safety Valves
- Isolation Valves
- Centrifugal Pumps
- Positive Displacement Pumps



Control Valve – Sizing and Selection

- Metric and English Units
- Cv, Noise, Velocity calculations
- Cavitation Prediction, Flashing, Choked flow
- Calculations for severe service valves/special trims
- Gas, Liquid, Two-Phase, Mixtures
- Fluid properties and database
- Provision to enter up to 20 Service conditions
- Drawings (CAD and other formats)
- Flow Curves, travel %
- Actuator Sizing and Selection Linear/Rotary
- Materials, Positioners, Accessories selection
- Inspection and Test Plans (ITP)
- Spec Sheets, Calculation sheet and technical reports
- ASME B16.34 / DN - EN 1092-1



Parameters	UOM	Cond-1	Cond-2	Cond-3	Cond-4	Cond-5
Liquid Flow	kg/h	25001	25000	25000	25000	
Inlet Pressure	bar a	10	18	19	28	
Outlet Pressure	bar a	8	1.01	1.01	1.01	
Pressure Drop	bar	2	16.99	17.99	26.99	
Inlet Temperature	deg C	15	15	15	15	
Specific Gravity		1.003	1.003	1.003	1.003	
Vapour Pressure	bar a	0.0171	0.0171	0.0171	0.0171	
Critical Pressure	bar a	221.3	221.3	221.3	221.3	
Viscosity	Centipoise	1.137	1.137	1.137	1.136	
Calculated Cv		20.48	7.025	6.827	5.574	
Travel	% Open	28	2	1	0	
Design Cv/Calculated Cv		17.58	51.25	52.73	64.59	
Pressure Recovery Factor		0.979	0.991	0.991	0.992	
Sigma		4.991	1.058	1.055	1.037	
Sigma MR		1.19	1.19	1.19	1.19	
Cavitation Index		-7.288	0.0598	0.113	0.627	
Fluid State		Normal Flow	Incipient Cav.	Cavitation	Severe Cav.	
Predicted Noise @ 1 Meter	dBa	45.57	67.55	68.05	71.43	
Inlet/Outlet Velocity	m/s	0.329	0.329	0.329	0.329	
Pipework Correction Factor		1	1	1	1	
Viscosity Correction Factor		1	1	1	1	
Energy Level	MW	0.00139	0.0118	0.0125	0.0187	
IEC Noise Level	dBa	33.96	57.46	57.22	55.43	
Trim Exit Velocity	m/s	13.62	39.72	40.87	50.06	
Max Trim Velocity	m/s	13.62	39.72	40.87	50.06	

Actuator Selection

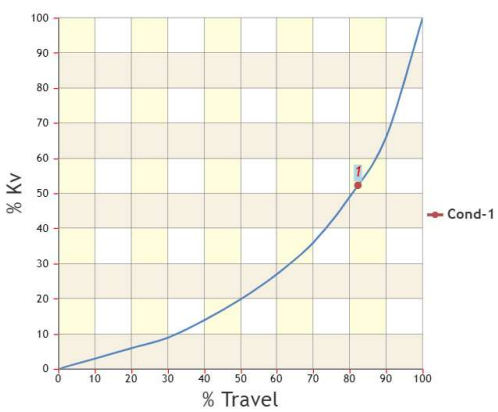
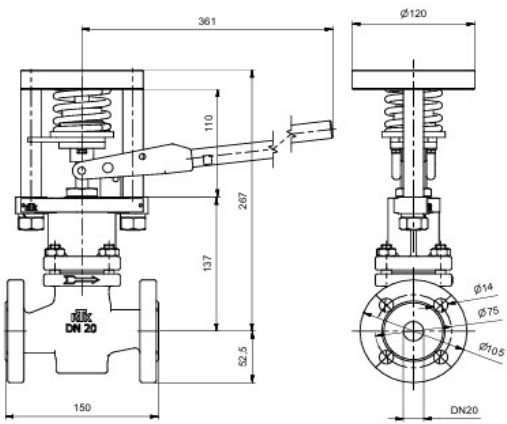

VALVE SPECIFICATION

Product	Globe	Function	Control
Guiding	Cage Guided	ASME Class	ANSI 300
Seat Type	Single Seated	Nominal Size	40 mm
End Bore	40 mm	Mark No.	3 (MK3 Valves)
Separate Seat	Yes	Flow Direction	Over
Trim Design	Multi-Flow	Flow Char	Eq%
Design Cv	19	Valve Travel	28.5
Leakage Class	ANSI Class IV	Bonnet Form	Standard
Plug Type	Solid	Shaft Orientation	Vertical
Gland Packing Type	Single		

RATING REQUIREMENTS

Body	ASTM A216 WCB	Interpolated Class	151
Body Rating	AutoSelect	Min Pressure Class	300
Rating Table Years	2020	Based on Group 1.1 standard class metric table (2020)	



Features

- Hosting - Azure Cloud and On-Premise
- APIs for Data Exchange
- GDPR compliance
- CRM integration
- ERP Integration
- Migration from legacy Tool
- Advance Pricing
- RFQ Import
- 2D/CAD Drawing
- Quotation management
- Azure built-in Security
- Guided selling
- Proposal Generation
- Quotation Sharing
- User levels - Internal Sales, Channel Partners, End Customers
- Advance Pricing
 - List based
 - Cost plus
 - Multipliers, discounts and approvals
 - Contract Management
 - Configurable and Non-configurable Lines
 - Adders, Spares (recommended and commissioning)
 - Price Schedule
 - Commissions

Download



Our team

- A dedicated team of engineers, domain experts and software professionals committed to delivering innovative and reliable CPQ solutions tailored to your business needs.
- With decades of combined experience in manufacturing, automation and software engineering, our team brings proven expertise and fresh thinking to every customer engagement.
- Strong track record of delivering consistent results and exceeding client expectations.
- Collaborative and client-centric approach, ensuring personalized solutions tailored to individual needs and goals.

Our customers

- Flowserve
- VSI
- Trillium
- RTK
- Celeros
- L&T
- Dresser
- SPX FLOW
- Bray
- KSB
- CIRCOR
- ARI
- WEIR
- DFT



Book a demo

- Book a demo today to experience streamlined quoting, precision sizing and effortless configuration in one CPQ solution.
- See how your sales team can deliver faster, more accurate quotes with automated sizing and selection.
- Discover how automation and accuracy can transform your sales process from quote to close.
- Unlock faster quoting, reduced errors and more wins for your sales team.



Scan to book a demo

Contact us

Shoppers Orbit

Alandi Road

Pune, India

sales@configuratorsolutions.com

www.configuratorsolutions.com

